

**wilo**

# DRAINAGE PUMP OWNER'S MANUAL

MODEL :  
PD-S401E/EA  
PD-S751E/EA  
PD-S401M/MA  
PD-S751M/MA

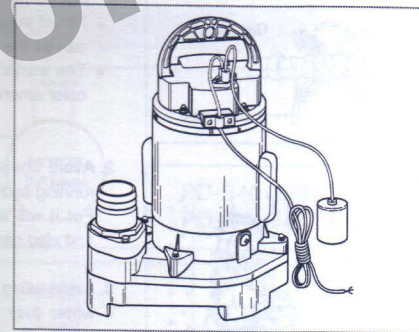

READ OVER THIS OWNER'S MANUAL BEFORE  
THE FIRST OPERATION OF YOUR PUMP FOR THE  
SAKE OF ITS OPTIMUM EFFICIENCY.

## PRECAUTION BEFORE USING THE PUMP

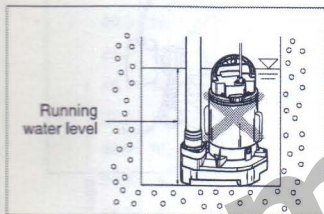
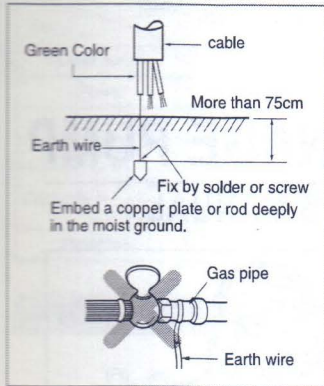

1. Connect the earth wire before use. This enable you to prevent an accident caused by electric shock when the electric insulation is not in order.
    - For your safety from the danger of electric shock, the circuit breaker should be installed.
- \*CAUTION IN CONNECTING THE EARTH WIRE.**
- Connect the earth wire after turning off the electric power.
  - Never connect with gas pipes, otherwise it can be the cause of explosion.
  - The earth wire of cable should be Green color among 3 wire.

2. Avoid operating under the condition of dry running and delivering no water. For it will shorten the service life of pump and also cause the trouble of motor.
3. Avoid using the pump under condition of hot water over 40 °C. For it will be shorten the service life of pump.
4. Be careful not to use the pump solvent such as benzol, acid, inflammable liquids such as gasoline. When it is used for them, there is the risk of the fire and it will cause the trouble of the pump and also shorten the service life of it.

## PRECAUTION BEFORE USING THE PUMP

5. Take care of handling the pump. Prohibit to impact the pump.

- Never carry the pump by the holding of cable itself.
- Care should be taken during installation that the pump is not allowed to be mounted suspended freely on the delivery pipe or on the cable. It must rest on a stabile surface and/or be suspended on a handle with a rope.

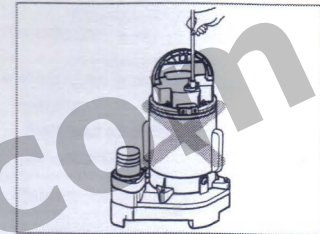

6. The permitted voltage of this pump is  $\pm 10\%$  of the rated voltage. Otherwise it will be the reason of shortening the service life of the pump.

7. When connect or disconnect an electric power to the pump for service, installation and repair, it should be cut off the electric switch.
  - Electric connections must be protected from moisture.

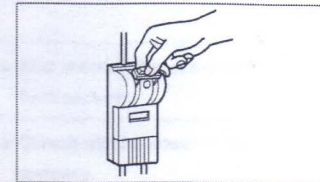

## AREAS OF USE

- This pump is used primarily as a cellar pump.
- This pump can, however, be used everywhere, where water is to be moved, for instance in the household, in farming, in the garden or yard, in sanitation installations, and in many other ways as well.
- Depending on the water level, the float switch's length can be controlled.



## APPEARANCE AND NAME OF PARTS

※ Before using, please check all parts of the pump. The pump consists of:

PD-S401E/EA , PD-S751E/EA  
 PD-S401M/MA , PD-S751M/MA

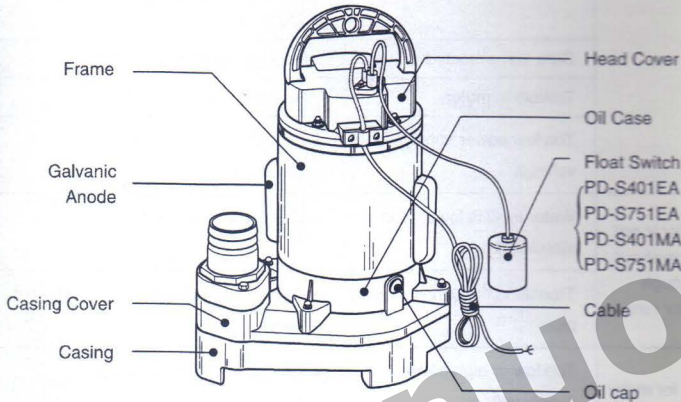

### Accessory



Hose coupling

## REPAIR AND CHECKING

- We recommend regular inspection and maintenance to ensure long equipment life and uninterrupted operation.
- Checking and exchange for oil.  
 It will be suitable for checking once per 3-6 month and exchange once per 1 year. And the exchanging oil will be Turbine oil #32 or the same as it.
- When pour oil into the oil chamber, it will be suitable 80-85% of its capacity(about 410cc).

## WIRING DIAGRAM

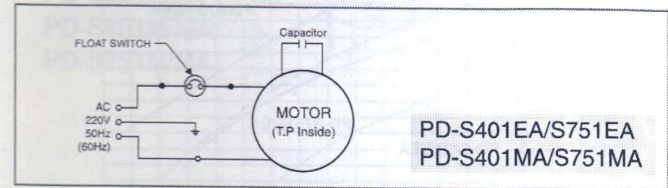
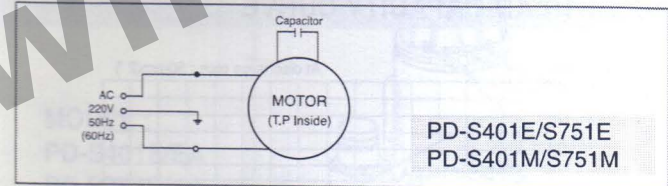

• Note:

※ T.P : Thermal protector

## SPECIFICATIONS

Item \ Model	PD-S401M/MA	PD-S401E/EA	PD-S751M/MA	PD-S751E/EA
Power source	220V 60Hz	220V 50Hz	220V 60Hz	220V 50Hz
Power	780W	600W	1500W	950W
Out put	400W	400W	750W	750W
Total head	13m(42.6ft)	9m(29.5ft)	18m(59ft)	12m(39.4ft)
Capacity	(l/min)	180(Ht=7m)	300(Ht=7m)	220(Ht=7m)
	(Gal/min)	47.52(Ht=22.9ft)	39.6(Ht=16.4ft)	79.2(Ht=22.9ft)
Pipe(mm)	50mm(2")			

## TOTAL HEAD-CAPACITY CURVE

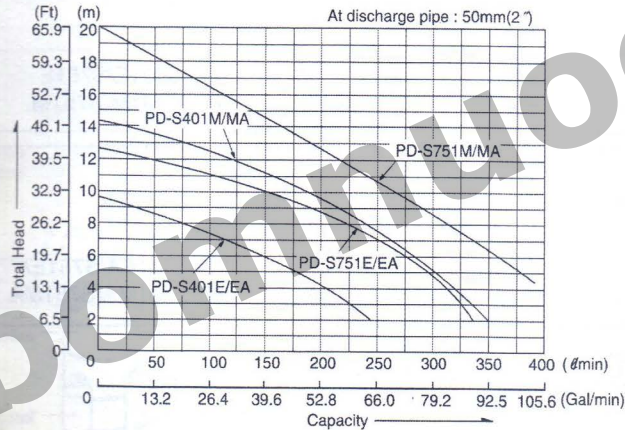

## TROUBLES AND COUNTER-MEASURES

Troubles	Cause	Counter-Measures (The indication ● can be done by user.)
Motor does not start.	T.P	<ul style="list-style-type: none"> <li>● If the motor is overheated, it doesn't operate. Then, wait till getting cold. (20~30 minutes)</li> </ul>
	Cord disconnected.	Replace the new cord.
	Trouble in motor.	Repair or replace the motor.
Water is not pumped out although motor runs.	Too low power supply voltage.	<ul style="list-style-type: none"> <li>● Consult with the power supply company.</li> </ul>
	Water level is lower than standard level	<ul style="list-style-type: none"> <li>● Check the water level</li> </ul>
T.P for motor works too often.	Trouble in the connection pipe.	<ul style="list-style-type: none"> <li>● After checking the joint of piping shut them perfectly.</li> </ul>
	Too low or high power supply voltage.	<ul style="list-style-type: none"> <li>● Consult with the power supply company.</li> </ul>
	Impeller is in contact with another part.	Repair the defects.
	Short or open circuit of the capacitor.	Replace the capacitor.