

Wilo-Drain STS 40/...A, STS 40/...

- | | |
|--|---|
| D Einbau- und Betriebsanleitung | H Beépítési és üzemeltetési utasítás |
| GB Installation and operating instructions | PL Instrukcja montażu i obsługi |
| F Notice de montage et de mise en service | CZ Návod k montáži a obsluze |
| NL Inbouw- en bedieningsvoorschriften | RUS Инструкция по монтажу и эксплуатации |
| E Instrucciones de instalación y funcionamiento | EST Paigaldus- ja kasutusjuhend |
| I Istruzioni di montaggio, uso e manutenzione | LV Instalēšanas un ekspluatācijas instrukcijas |
| P Manual de instalação e funcionamento | LT Montavimo ir naudojimo instrukcija |
| TR Montaj ve kullanma kılavuzu | SK Návod na montáž a obsluhu |
| GR Οδηγίες εγκατάστασης και λειτουργίας | SLO Navodila za vgradnjo in vzdrževanje |
| S Monterings- och skötselanvisning | BG Инструкция за монтаж и експлоатация |
| FIN Asennus- ja käyttöohje | RO Instrucțiuni de montaj și exploatare |
| DK Monterings- og driftsvejledning | |

Fig.1:

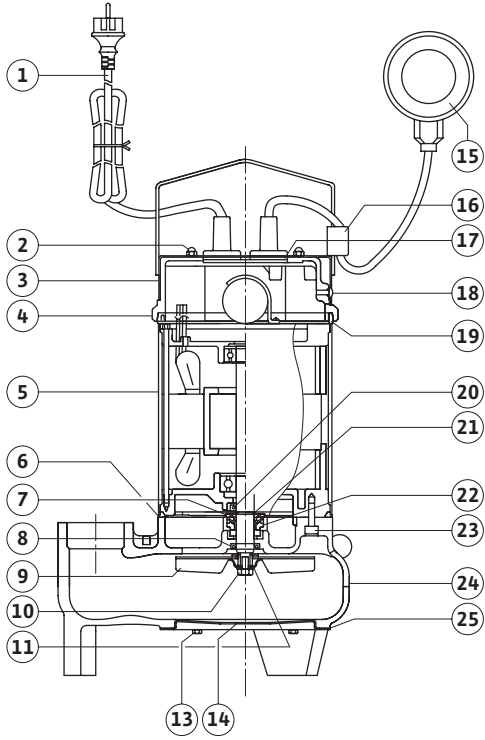

Fig. 2a

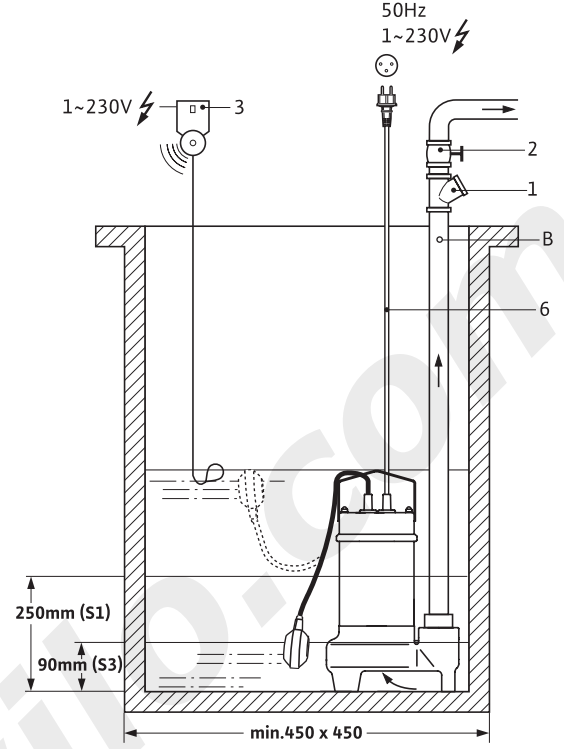

Fig. 2b

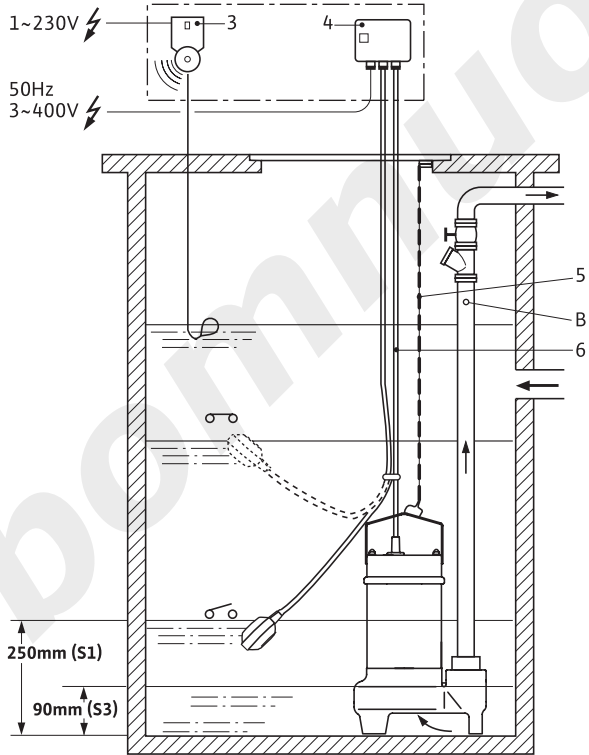
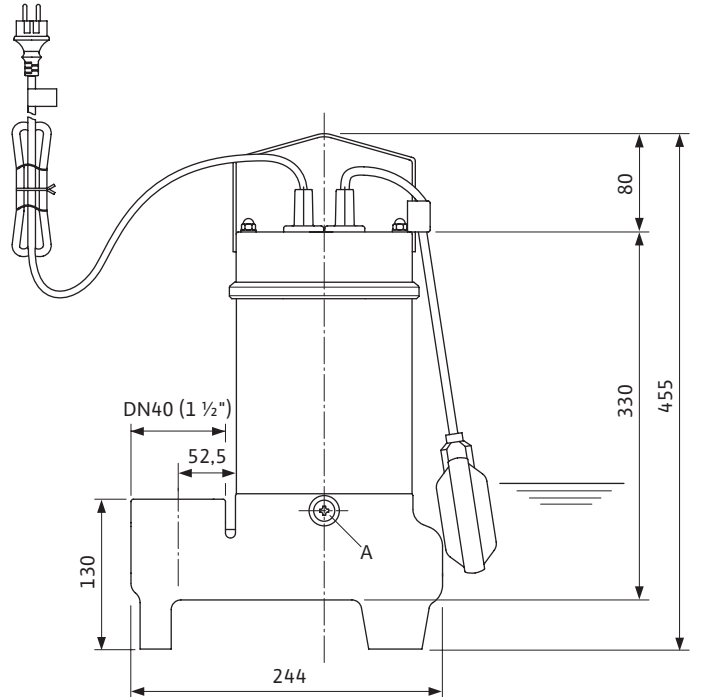

Fig.3:



D	Einbau- und Betriebsanleitung	3
GB	Installation and operating instructions	8
F	Notice de montage et de mise en service	13
NL	Inbouw- en bedieningsvoorschriften	19
E	Instrucciones de instalación y funcionamiento	24
I	Istruzioni di montaggio, uso e manutenzione	29
P	Manual de instalação e funcionamento	34
TR	Montaj ve kullanma kılavuzu	39
S	Monterings- och skötselanvisning	44
FIN	Asennus- ja käyttöohje	49
DK	Monterings- og driftsvejledning	54
PL	Instrukcja montażu i obsługi	59
GR	Οδηγίες εγκατάστασης και λειτουργίας	65
CZ	Návod k montáži a obsluze	71
RUS	Инструкция по монтажу и эксплуатации	76
EST	Paigaldus- ja kasutusjuhend	82
LV	Instalācijas un ekspluatācijas instrukcija	87
H	Beépítési és üzemeltetési utasítás	92
LT	Montavimo ir naudojimo instrukcija	97
SK	Návod na montáž a obsluhu	102
BG	Инструкция за монтаж и експлоатация	107
SLO	Navodila za vgradnjo in vzdrževanje	113
RO	Instrucțiuni de montaj și exploatare	118

bomnuocwilo.com

1 General

About this document

These installation and operating instructions are an integral part of the product. They must be kept readily available at the place where the product is installed. Strict adherence to these instructions is a precondition for the proper use and correct operation of the product.

These installation and operating instructions correspond to the relevant version of the product and the underlying safety standards valid at the time of going to print.

2 Safety

These operating instructions contain basic information which must be adhered to during installation and operation. For this reason, these operating instructions must, without fail, be read by the service technician and the responsible operator before installation and commissioning. It is not only the general safety instructions listed under the main point "safety" that must be adhered to but also the special safety instructions with danger symbols included under the following main points.

2.1 Indication of instructions in the operating instructions

Symbols:
General danger symbol



Danger due to electrical voltage



NOTE: ...



Signal words:

DANGER!

**Acutely dangerous situation.
Non-observance results in death or the most serious of injuries.**

WARNING!

The user can suffer (serious) injuries. 'Warning' implies that (serious) injury to persons is probable if this information is disregarded.

CAUTION!

There is a risk of damaging the pump/unit. 'Caution' implies that damage to the product is likely if the information is disregarded.

HINWEIS: Useful information on using the product. It draws attention to possible problems.

2.2 Personnel qualifications

The installation personnel must have the appropriate qualification for this work.

2.3 Danger in event of non-observance of the safety instructions

Non-observance of the safety instructions can result in risk of injury to persons and damage to pump/unit. Non-observance of the safety instructions can result in the loss of any claims to damages.

In detail, non-observance can, for example, result in the following risks:

- Failure of important pump/unit functions
- Failure of required maintenance and repair procedures
- Danger to persons from electrical, mechanical and bacteriological influences
- Property damage

2.4 Safety instructions for the operator

The existing directives for accident prevention must be adhered to.

Danger from electrical current must be eliminated. Local directives or general directives [e.g. IEC, VDE etc.] and local power supply companies must be adhered to.

2.5 Safety instructions for inspection and installation work

The operator must ensure that all inspection and installation work is carried out by authorised and qualified personnel, who are sufficiently informed from their own detailed study of the operating instructions.

Work to the pump/unit must only be carried out when at a standstill.

2.6 Unauthorised modification and manufacture of spare parts

Alterations to the pump/unit are only permissible after consultation with the manufacturer. Original spare parts and accessories authorised by the manufacturer ensure safety. The use of other parts can nullify the liability from the results of their usage.

2.7 Improper use

The operating safety of the supplied pump/unit is only guaranteed for conventional use in accordance with section 4 of the operating instructions. The limit values must on no account fall under or exceed those specified in the catalogue/data sheet.

3 Transport and interim storage

As soon as the product arrives:

- check product for any damage in transit,
- If damage has occurred, take the necessary steps, within the defined periods, with the transport company.



CAUTION! Danger of material damage!

The product may be damaged if it is not transported and stored correctly.

- **For transport, the pump may only be lifted or carried using the brackets intended for that purpose. The cable should never be used for lifting!**
- **During transport and temporary storage, the pump must be protected from moisture, from frost and from mechanical damage.**

4 Intended use

Wilo-Drain STS 40 submersible pumps are suitable for pumping sewage, waste water and clean fluids containing solid particles of up to 40 mm diameter from shafts, pits and containers.

They are used for the following applications:

- Domestic drainage
- Sewage and water supply
- Environment and waste water treatment
- Industrial and process engineering



NOTE: Follow the locally applicable regulations for the intended application.

The pumps are usually installed flooded (immersed) and can only be installed vertically, whether fixed or mobile.

Submersible motor pumps with connection lines of less than 10 m are only approved (according to EN 60335) for use within buildings, not for outdoor use.



DANGER! Risk of fatal injury!

The pump may not be used to empty swimming pools / garden ponds or similar locations if there are people in the water.



WARNING! Health risk!

Owing to the materials used, the pumps are not suitable for drinking water! Dirty water poses a risk to health.



CAUTION! Danger of material damage!

Pumping materials which are not approved can lead to damage to the product.

The pumps are not suitable for water containing coarse impurities such as sand, fibres or flammable liquids, or for use in areas at risk of explosion.

Use of the product as intended also means following these instructions.

Use over and beyond the use described is not use as intended.

5 Product information

5.1 Type key

Example:	
STS 40/8 A 1-230-50-2-5M KA	
STS 40/10 3-400-50-2-10M KA	
STS	Series: ST = Sewage Technology S = Stainless Steel Motor
40	Nominal diameter of the discharge port [mm]: 40 = Rp 1½
/8	Max. delivery head [m] for Q=0m³/h: 8, 10
A	A = with float switch, - = not specified: without float switch,
1-230	Mains voltage: 1~230 V, single-phase motor, 3~400 V, three-phase motor
-50	Mains frequency [Hz]
-2	2 poles
5M KA	Length of electrical cable [m]: 5, 10

5.2 Technical data

Permissible fluid components:	Slightly acidic / slightly alkaline, maximum chloride content 150 mg/l (for 1.4301 / AISI 304)
Max particle size:	40 mm
Mains voltage:	1~230 V, ± 10 %, 3~400 V, ± 10 %
Mains frequency:	50 Hz
Protection class:	IP 68
Speed:	Max. 2900 /min (50 Hz)
Max. current consumption:	See name plate
Power consumption P1:	See name plate
Rated motor power P2:	See name plate
Max. flow rate:	See name plate
Max. delivery head:	See name plate
Operating mode S1:	200 operating hours per year
Operating mode S3 (optimum):	Intermittent duty, 25 % (2.5 min. operation, 7.5 min. pause).
Recommended switching frequency:	20/h
Max. starts per hour:	50/h
Nominal diameter of the pressure port:	See type key
Permissible temperature range of the pumped liquid:	+3 to 35 °C
Max. immersion depth:	5 m
Noise level at min. level:	< 70 db(A)
Oil filling:	ELFOLNA DS 22 or equivalent, approx. 0,4 l

5.3 Scope of delivery

Pump is delivered with

- 5 or 10 m electrical connection cable (depending on version),
 - single-phase version with mains plug (CEI 23-5),
 - three-phase version with free cable end.

- Connected float switch (Wilo-Drain STS 40),
- Installation and operating instructions

5.4 Accessories

Accessories must be ordered separately:

- Switchgear for 1 or 2-pump operation
- external monitoring devices / tripping units
- level controller (level sensor / float switch)
- Accessories for transportable wet-well installation
- Accessories for stationary wet-well installation

6 Description and function

6.1 Description of the pump (Fig. 1)

Pos.	Description of component
1	Electrical connection cable
2	Cap nut
3	Cover with handle
4	Cover holder
5	Motor housing
6	Oil chamber seal cover
7	Oil chamber seal
8	Shaft seal ring
9	Impeller
10	Screw
11	Washer
13	Screw
14	Feed plate
15	Float switch
16	Cable holder
17	Cable entry seal
18	Screw
19	Motor cover seal
20	Shaft seal ring
21	Snap ring
22	Mechanical seal
23	Screw
24	Pump housing
25	Seal

The pump is made of stainless steel (motor) and cast iron (hydraulics).

It is driven by a water pressure-tight, encapsulated motor. The pump and the motor have a shared shaft. The fluid comes up through the central suction opening and is pumped out through the vertical discharge port.

The pumps are equipped with a single-stage VORTEX impeller. It pumps solids of diameters up to 40 mm diameter (not fibrous solids such as grass, leaves and rags).

The pump is either permanently installed and bolted to a fixed pressure pipe (R 1 ½), or set up portably and connected to a hose.

The motor chamber is sealed from the pump chamber using a mechanical seal on the fluid side and a radial shaft seal on the motor side. To ensure that the mechanical seal is always lubricated and cooled, even when running dry, the mechanical seal chamber is filled with oil.

The motors have thermal protection, switching off the motor automatically on overheating, and

switching it on again after cooling down. The single-phase motor has a capacitor to generate the rotating magnetic field.

7 Installation and electrical connection

DANGER! Risk of fatal injury!

Improper installation and improper electrical connections can result in a risk of fatal injury.

- **The installation and electrical connections should only be done by properly skilled staff and in compliance with applicable regulations!**
- **Follow all accident prevention regulations!**



7.1 Installation

The pump was designed both for fixed and for mobile installation.

CAUTION! Danger of material damage!

Danger of damage due to improper handling.

Lift the pump using a chain or a rope attached to the handle. Never lift using the power / float switch cable or the pipe / hose connection.

The installation site or pit for the pump must be free of frost.

The pit must be cleared of coarse material such as rubble before setting up and starting the pump. For the installation dimensions see the drawing (Fig 3), pit dimension (Fig 2a).

The pressure pipe must have the same nominal width as the pump (R 1 ½", can be enlarged).

It is essential that the pit allows the float switch to move freely (Wilo-Drain STS 40).



7.1.1 Stationary wet installation (Fig. 2a, 2b)

- 1 Non-return valve
- 2 Isolating valve
- 3 Overflow alarm control
- 4 Switchgear with connected float switch for pump operation
- 5 Chain
- 6 Electrical connection motor cable

Fig. 2a:

Pump (Wilo-Drain STS 40) with single-phase motor and optional overflow alarm control.

Fig. 2b:

Pump with three-phase motor. Switchgear with connected float switch for one pump operation and optional overflow alarm control.

For stationary wet installation with a fixed pressure pipe, the pump must be positioned and fastened to ensure the following:

- The connection to the pressure pipe does not bear the weight of the pump
- The load of the pressure pipe does not act on the connection port

Provide a 4 mm diameter hole on the discharge pipe before the check valve for a possible venting following a draining (Fig. 2a, 2b Pos. B)

7.1.2 Portable wet installation

For portable wet installation with hose connection, the pump must be secured in the pit against moving or falling over (e.g. fix the chain with a small amount of tension).



NOTE: When used in a pit without a firm base, the pump must be put on a sufficiently large plate or hung from a rope or a chain in a suitable position.

7.2 Electrical connection



DANGER! Risk of fatal injury!

If the electrical connection is not made properly, there is a risk of fatal injury from an electric shock.

The electrical connection must be made by an electrician approved by the local energy supply company in compliance with the applicable local regulations.

- The type of power supply (single phase or 3 phase) and its voltage must correspond to the specifications on the name plate
- Fuse in the power supply: 16 A, slow blow
- Earth the system as required by regulations
- Using a residual current device ≤ 30 mA
- Using a mains disconnection device with an opening of at least 3 mm
- The pump is ready for connection.

Pump with three-phase motor (3~400V):

For the three-phase connection, connect the wires at the free end of the cable as follows:

4-wire connection cable: 4x1,0 mm²

Wire	Terminal
brown	U
black	V
blue	W
green/yellow	PE

Wire up the free end of the cable in the switch box (see the installation and operating instructions of the switch box).

8 Commissioning



DANGER! Beware of electric shock!

The pump may not be used to empty swimming pools, garden ponds or similar if there are people in the water.



CAUTION! Danger of material damage!

Before installation, clean the pond and the supply pipes from all solid materials such as rubble.

8.1 Checking the direction of rotation (three-phase motors only)



NOTE: If the pump is running in the wrong sense, the flow is significantly reduced.

You must check the direction of rotation of the pump **before** you immerse it. An arrow on the top of the motor housing shows the correct direction of rotation.

- Hold the pump in your hand.
- Switch the pump on briefly. The pump recoils in the opposite direction (anticlockwise) to the motor's direction of rotation.
- If the direction of rotation is incorrect, swap two phases of the mains connection.

8.2 Adjusting the level control



CAUTION! Danger of material damage!

Do not allow the mechanical seal to run dry.

Dry running shortens the life of the motor and the mechanical seal. If the mechanical seal is damaged, small amounts of oil may escape into the pumped fluid.

- The water level may not sink below the minimum pump immersion depth. Set the level control to the following minimum level: Fig. 2a, 2b
 - Min 90 mm: Operating mode S3: see Technical data
 - Min 250 mm: Operating mode S1: see Technical data
- When filling the shaft or powering the pump into the pit, make sure the float switch (Wilo-Drain STS 40) can move freely.
- Switch on the pump.

9 Maintenance

Maintenance and repairs may only be carried out by qualified experts!

WARNING! Beware of infection!

Wear suitable protective clothing (safety gloves) for maintenance in order to prevent any risk of infection.

Danger! Beware of fatal injury!

When working on electrical equipment, there is a risk of a fatal shock.

- **For all maintenance and repair work on the pump, it must be electrically isolated and unauthorised switch-on must be prevented.**
- **Any damage to the connection cable must always be repaired by a properly qualified electrician.**
- Change the oil in the mechanical seal chamber once a year.
 - Unscrew the oil drain plug with seal ring (Fig. 3, Pos. A).
 - Lay the pump on its side until oil flows out (catch it in a suitable receptacle and take it for proper disposal).
- NOTE: When you change the oil, the old oil and water have to be disposed of as hazardous waste. The oil is not biodegradable.
- Fill the pump with new oil (see Technical data).
- Screw in the oil drain plug and seal ring.



10 Faults, causes and remedies**Only allow faults to be remedied by qualified****personnel!****Follow the safety instructions in Maintenance.**

Fault	Cause	Remedy
Pump does not start	No voltage	Check the wires and fuses, or switch automatic fuses in the distribution station back on
	Rotor blocked	Clean the housing and impeller, if still blocked replace the pump
	Cable rupture	Check the cable resistance. If necessary, replace the cable. Only use genuine Wilo special cable.
Safety switches thrown	Water in the motor chamber	Contact customer service
	Foreign bodies in the pump, winding protection contact triggered	Disconnect the system from the electricity supply and secure it against being switched on. Lift the pump out of the sump. Remove the objects.
Pump has no power	Pump drawing up air because fluid level is too low	Check the function/setting of the level control
	Pressure pipe blocked	Detach the pipe and clean it

If the fault can't be fixed, please contact your local specialist or your nearest <Wilo><Salmson> customer service location or representative.

11 Spare parts

Spare parts can be ordered from your local specialist and/or via <Wilo><Salmson> customer service.

To avoid queries and incorrect orders, always provide all of the details on the name plate with every order.

Subject to change without prior notice!

D **EG – Konformitätserklärung**
GB **EC – Declaration of conformity**
F **Déclaration de conformité CEE**

Hiermit erklären wir, dass die Bauarten der Baureihe : **STS 40/8**
 Herewith, we declare that this product: **STS 40/10**
 Par le présent, nous déclarons que cet agrégat :

in der gelieferten Ausführung folgenden einschlägigen Bestimmungen entspricht:
 in its delivered state comply with the following relevant provisions:
 est conforme aux dispositions suivants dont il relève:

EG-Maschinenrichtlinie **98/37/EG**
EC-Machinery directive
Directives CEE relatives aux machines

Elektromagnetische Verträglichkeit – Richtlinie **89/336/EWG**
Electromagnetic compatibility – directive i.d.F/ as amended/ avec les amendements suivants:
Compatibilité électromagnétique- directive 91/263/EWG
 92/31/EWG
 93/68/EWG

Niederspannungsrichtlinie **73/23/EWG**
Low voltage directive i.d.F/ as amended/ avec les amendements suivants :
Direction basse-tension 93/68/EWG

Bauproduktenrichtlinie **89/106/EWG**
Construction product directive i.d.F/ as amended/ avec les amendements suivants :
Directive de produit de construction 93/68/EWG

Angewendete harmonisierte Normen, insbesondere:
 Applied harmonized standards, in particular:
 Normes harmonisées, notamment:

EN 809
EN 12050-2
EN 60034-1
EN 60204-1
EN 60335-2-41
EN 61000-6-3
EN 61000-6-4

Dortmund, 06.04.2006

i. V.

 Erwin Prieß
 Quality Manager



WILO AG
 Nortkirchenstraße 100
 44263 Dortmund

<p>NL EG-verklaring van overeenstemming Hiermede verklaren wij dat dit aggregaat in de geleverde uitvoering voldoet aan de volgende bepalingen: EG-richtlijnen betreffende machines 98/37/EG Elektromagnetische compatibiliteit 89/336/EEG als vervolg op 91/263/EEG, 92/31/EEG, 93/68/EEG EG-laagspanningsrichtlijn 73/23/EEG als vervolg op 93/68/EEG Bouwproductenrichtlijn 89/106/EEG als vervolg op 93/86/EEG Gebruikte geharmoniseerde normen, in het bijzonder: 1)</p>	<p>I Dichiarazione di conformità CE Con la presente si dichiara che i presenti prodotti sono conformi alle seguenti disposizioni e direttive rilevanti: Direttiva macchine 98/37/CE Compatibilità elettromagnetica 89/336/CEE e seguenti modifiche 91/263/CEE, 92/31/CEE, 93/68/CEE Direttiva bassa tensione 73/23/CEE e seguenti modifiche 93/68/CEE Direttiva linee guida costruzione dei prodotti 89/106/CEE e seguenti modifiche 93/68/CEE Norme armonizzate applicate, in particolare: 1)</p>	<p>E Declaración de conformidad CE Por la presente declaramos la conformidad del producto en su estado de suministro con las disposiciones pertinentes siguientes: Directiva sobre máquinas 98/37/CE Directiva sobre compatibilidad electromagnética 89/336/CEE modificada por 91/263/CEE, 92/31/CEE, 93/68/CEE Directiva sobre equipos de baja tensión 73/23/CEE modificada por 93/68/CEE Directiva sobre productos de construcción 89/106/CEE modificada por 93/68/CEE Normas armonizadas adoptadas, especialmente: 1)</p>
<p>P Declaração de Conformidade CE Pela presente, declaramos que esta unidade no seu estado original, está conforme os seguintes requisitos: Directivas CEE relativas a máquinas 98/37/CE Compatibilidade electromagnética 89/336/CEE com os aditamentos seguintes 91/263/CEE, 92/31/CEE, 93/68/CEE Directiva de baixa voltagem 73/23/CEE com os aditamentos seguintes 93/68/CEE Directiva sobre produtos de construção 89/106/CEE com os aditamentos seguintes 93/68/EEG Normas harmonizadas aplicadas, especialmente: 1)</p>	<p>S CE- försäkrän Härmed förklarar vi att denna maskin i levererat utförande motsvarar följande tillämpliga bestämmelser: EG-Maskindirektiv 98/37/EG EG-Elektromagnetisk kompatibilitet – riktlinje 89/336/EEG med följande ändringar 91/263/EEG, 92/31/EEG, 93/68/EEG EG-Lågspänningsdirektiv 73/23/EEG med följande ändringar 93/68/EEG EG-Byggmaterialdirektiv 89/106/EEG med följande ändringar 93/68/EEG Tillämpade harmoniserade normer, i synnerhet: 1)</p>	<p>N EU-Overensstemmelseserklæring Vi erklærer hermed at denne enheten i utførelse som levert er i overensstemmelse med følgende relevante bestemmelser: EG-Maskindirektiv 98/37/EG EG-EMV-Elektromagnetisk kompatibilitet 89/336/EEG med senere tilføyelser: 91/263/EEG, 92/31/EEG, 93/68/EEG EG-Lavspenningsdirektiv 73/23/EEG med senere tilføyelser: 93/68/EEG Byggevaredirektiv 89/106/EEG med senere tilføyelser 93/68/EEG Anvendte harmoniserte standarder, særlig: 1)</p>
<p>FIN CE-standardinmukaisuuseloste Ilmoitamme täten, että tämä laite vastaa seuraavia asiaankuuluvia määräyksiä: EU-konedirektiivit: 98/37/EG Sähkömagneettinen soveltuvuus 89/336/EEG seuraavien täsmennyksien 91/263/EEG, 92/31/EEG, 93/68/EEG Matalajännite direktiivit: 73/23/EEG seuraavien täsmennyksien 93/68/EEG EU materiaalidirektiivi 89/106/EEG seuraavien täsmennyksien 93/68/EEG Käytetyt yhteensovitetut standardit, erityisesti: 1)</p>	<p>DK EF-overensstemmelseserklæring Vi erklærer hermed, at denne enhed ved levering overholder følgende relevante bestemmelser: EU-maskindirektiver 98/37/EG Elektromagnetisk kompatibilitet: 89/336/EEG, følgende 91/263/EEG, 92/31/EEG, 93/68/EEG Lavvolts-direktiv 73/23/EEG følgende 93/68/EEG Produktkonstruktionsdirektiv 98/106/EEG følgende 93/68/EEG Anvendte harmoniserede standarder, særligt: 1)</p>	<p>H EK. Azonossági nyilatkozat Ezennel kijelentjük, hogy az berendezés az alábbiaknak megfelel: EK Irányelvek gépekhez: 98/37/EG Elektromágneses zavarás/tűrés: 89/336/EEG és az azt kiváltó 91/263/EEG, 92/31/EEG, 93/68/EEG Kisfeszültségű berendezések irányelve: 73/23/EEG és az azt kiváltó 93/68/EEG Építési termékek irányelv 98/106/EEG és az azt kiváltó 93/68/EEG Felhasznált harmonizált szabványok, különösen: 1)</p>
<p>CZ Prohlášení o shodě EU Prohlašujeme tímto, že tento agregát v dodaném provedení odpovídá následujícím příslušným ustanovením: Směrnícím EU–strojní zařízení 98/37/EG Směrnícím EU–EMV 89/336/EEG ve sledu 91/263/EEG, 92/31/EEG, 93/68/EEG Směrnícím EU–nízké napětí 73/23/EEG ve sledu 93/68/EEG Směrnícím stavebních produktů 89/106/EEG ve sledu 93/68/EEG Použité harmonizační normy, zejména: 1)</p>	<p>PL Deklaracja Zgodności CE Niniejszym deklarujemy z pełną odpowiedzialnością że dostarczony wyrób jest zgodny z następującymi dokumentami: EC–dyrektywa dla przemysłu maszynowego 98/37/EG Odpowiedniość elektromagnetyczna 89/336/EEG ze zmianą 91/263/EEG, 92/31/EEG, 93/68/EEG Normie niskich napięć 73/23/EEG ze zmianą 93/68/EEG Wyroby budowlane 89/106/EEG ze zmianą 93/68/EEG Wyroby są zgodne ze szczegółowymi normami zharmonizowanymi: 1)</p>	<p>RUS Декларация о соответствии Европейским нормам Настоящим документом заявляем, что данный агрегат в его объеме поставки соответствует следующим нормативным документам: Директивы ЕС в отношении машин 98/37/EG Электромагнитная устойчивость 89/336/EEG с поправками 91/263/EEG, 92/31/EEG, 93/68/EEG Директивы по низковольтному напряжению 73/23/EEG с поправками 93/68/EEG Директива о строительных изделиях 89/106/EEG с поправками 93/68/EEG Используемые согласованные стандарты и нормы, в частности : 1)</p>
<p>GR Δήλωση προσαρμογής της Ε.Ε. Δηλώνουμε ότι το προϊόν αυτό σ' αυτή την κατάσταση παράδοσης ικανοποιεί τις ακόλουθες διατάξεις : Οδηγίες EG για μηχανήματα 98/37/EG Ηλεκτρομαγνητική συμβατότητα EG-89/336/EEG όπως τροποποιήθηκε 91/263/EEG 92/31/EEG, 93/68/EEG Οδηγία χαμηλής τάσης EG-73/23/EEG όπως τροποποιήθηκε 93/68/EEG Οδηγία κατασκευής 89/106/EEG όπως τροποποιήθηκε 93/68/EEG Εναρμονισμένα χρησιμοποιούμενα πρότυπα, ιδιαίτερα: 1)</p>	<p>TR CE Uygunluk Teyid Belgesi Bu cihazın teslim edildiği şekliyle aşağıdaki standartlara uygun olduğunu teyid ederiz: AB-Makina Standartları 98/37/EG Elektromanyetik Uyumluluk 89/336/EEG ve takip eden, 91/263/EEG, 92/31/EEG, 93/68/EEG Alçak gerilim direktifi 73/23/EEG ve takip eden, 93/68/EEG Ürün imalat direktifi 89/106/EEG ve takip eden, 93/68/EEG Kismen kullanılan standartlar: 1)</p>	<p>1) EN 809, EN 12050-2, EN 60034-1, EN 60204-1 EN 60335-2-41, EN 61000-6-3, EN 61000-6-4.</p>

Erwin Pfeiß
Quality Manager

WILO

WILO AG
Nortkirchenstraße 100
44263 Dortmund

Wilo – International (Subsidiaries)**Austria**

WILO Handelsges. m.b.H.
 1230 Wien
 T +43 5 07507-0
 F +43 5 07507-42
 office@wilo.at

Azerbaijan

WILO Caspian LLC
 1014 Baku
 T +994 12 4992386
 F +994 12 4992879
 info@wilo.az

Belarus

WILO Bel OOO
 220035 Minsk
 T +375 17 2503393
 F +375 17 2503383
 wilobel@wilo.by

Belgium

WILO SA/ NV
 1083 Ganshoren
 T +32 2 4823333
 F +32 2 4823330
 info@wilo.be

Bulgaria

WILO Bulgaria Ltd.
 1125 Sofia
 T +359 2 9701970
 F +359 2 9701979
 info@wilo.bg

Canada

WILO Canada Inc.
 Calgary, Alberta T2A5L4
 T/F +1 403 2769456
 bill.lowe@wilo-na.com

China

WILO SALMSON (Beijing)
 Pumps System Ltd.
 101300 Beijing
 T +86 10 80493900
 F +86 10 80493788
 wilobj@wilo.com.cn

Croatia

WILO Hrvatska d.o.o.
 10090 Zagreb
 T +38 51 3430914
 F +38 51 3430930
 wilo-hrvatska@wilo.hr

Czech Republic

WILO Praha s.r.o.
 25101 Cestlice
 T +420 234 098 711
 F +420 234 098 710
 info@wilo.cz

Denmark

WILO Danmark A/S
 2690 Karlslunde
 T +45 70 253312
 F +45 70 253316
 wilo@wilo.dk

Estonia

WILO Eesti O
 12618 Tallinn
 T +372 6509780
 F +372 6509781
 info@wilo.ee

Finland

WILO Finland OY
 02330 Espoo
 T +358 207401540
 F +358 207401549
 wilo@wilo.fi

France

WILO S.A.S.
 78310 Coigny res
 T +33 1 30050930
 F +33 1 34614959
 info@wilo.fr

Great Britain

WILO (U.K.) Ltd.
 DE14 2WJ Burton-
 Upon-Trent
 T +44 1283 523000
 F +44 1283 523099
 sales@wilo.co.uk

Greece

WILO Hellas AG
 14569 Anixi (Attika)
 T +302 10 6248300
 F +302 10 6248360
 wilo.info@wilo.gr

Hungary

WILO Magyarorsz g Kft
 2045 T r kb lint
 (Budapest)
 T +36 23 889500
 F +36 23 889599
 wilo@wilo.hu

Ireland

WILO Engineering Ltd.
 Limerick
 T +353 61 227566
 F +353 61 229017
 sales@wilo.ie

Italy

WILO Italia s.r.l.
 20068 Peschiera
 Borromeo (Milano)
 T +39 255338351
 F +39 255303374
 wilo.italia@wilo.it

Kazakhstan

WILO Central Asia
 050002 Almaty
 T +7 3272 785961
 F +7 3272 785960
 in.pak@wilo.kz

Korea

WILO Pumps Ltd.
 621-807 Gimhae
 Gyeongnam
 T +82 55 3405809
 F +82 55 3405885
 wilo@wilo.co.kr

Latvia

WILO Baltic SIA
 1019 Riga
 T +371 7 145229
 F +371 7 145566
 mail@wilo.lv

Lebanon

WILO SALMSON
 Lebanon
 12022030 El Metn
 T +961 4 722280
 F +961 4 722285
 wsl@cyberia.net.lb

Lithuania

WILO Lietuva UAB
 03202 Vilnius
 T/F +370 2 236495
 mail@wilo.lt

Montenegro

WILO Beograd d.o.o.
 11000 Beograd
 T +381 11 2850410
 F +381 11 2851278
 office@wilo.co.yu

The Netherlands

WILO Nederland b.v.
 1948 RC Beverwijk
 T +31 251 220844
 F +31 251 225168
 info@wilo.nl

Norway

WILO Norge AS
 0901 Oslo
 T +47 22 804570
 F +47 22 804590
 wilo@wilo.no

Poland

WILO Polska Sp. z o.o.
 05-090 Raszyn
 T +48 22 7026161
 F +48 22 7026100
 wilo@wilo.pl

Portugal

Bombas Wilo-Salmson
 Portugal Lda.
 4050-040 Porto
 T +351 22 2076900
 F +351 22 2001469
 bombas@wilo-salmson.pt

Romania

WILO Romania s.r.l.
 041833 Bucharest
 T +40 21 4600612
 F +40 21 4600743
 wilo@wilo.ro

Russia

WILO Rus ooo
 123592 Moscow
 T +7 495 7810690
 F +7 495 7810691
 wilo@orc.ru

Serbia

WILO Beograd d.o.o.
 11000 Beograd
 T +381 11 2850410
 F +381 11 2851278
 office@wilo.co.yu

Slovakia

WILO Slovakia s.r.o.
 82008 Bratislava 28
 T +421 2 45520122
 F +421 2 45246471
 wilo@wilo.sk

Slovenia

WILO Adriatic d.o.o.
 1000 Ljubljana
 T +386 1 5838130
 F +386 1 5838138
 wilo.adriatic@wilo.si

Spain

WILO Iberica S.A.
 28806 Alcal de Henares
 (Madrid)
 T +34 91 8797100
 F +34 91 8797101
 wilo.iberica@wilo.es

Sweden

WILO Sverige AB
 35246 V xj
 T +46 470 727600
 F +46 470 727644
 wilo@wilo.se

Switzerland

EMB Pumpen AG
 4310 Rheinfelden
 T +41 61 8368020
 F +41 61 8368021
 info@emb-pumpen.ch

Turkey

WILO Pompa Sistemleri
 San. ve Tic. A.Ş.
 34857 Istanbul
 T +90 216 6610203
 F +90 216 6610212
 wilo@wilo.com.tr

Ukraine

WILO Ukraina t.o.w.
 01033 Kiev
 T +38 044 2011870
 F +38 044 2011877
 wilo@wilo.ua

USA

WILO-EMU LLC
 Thomasville, Georgia
 31758-7810
 T +1 229 584 0098
 F +1 229 584 0234
 terry.rouse@wilo-emu.com

USA

WILO USA LLC
 Calgary, Alberta T2A5L4
 T/F +1 403 2769456
 bill.lowe@wilo-na.com

Wilo – International (Representation offices)**Bosnia and Herzegovina**

71000 Sarajevo
 T +387 33 714510
 F +387 33 714511
 zeljko.cvjetkovic@wilo.ba

Georgia

0177 Tbilisi
 T/F +995 32317813
 info@wilo.ge

Macedonia

1000 Skopje
 T/F +389 2122058
 valerij.vojneski@wilo.com.mk

Moldova

2012 Chisinau
 T/F +373 2 223501
 sergiu.zagurean@wilo.md

Tajikistan

Dushanbe
 T +992 93 5554541

Uzbekistan

100046 Taschkent
 T/F +998 71 1206774
 info@wilo.uz

January 2007

WILO

WILO AG
 Nortkirchenstra e 100
 44263 Dortmund
 Germany
 T 0231 4102-0
 F 0231 4102-7363
 wilo@wilo.de
 www.wilo.de

Wilo-Vertriebsb ros in Deutschland

G1 Nord

WILO AG
 Vertriebsb ro Hamburg
 Beim Strohhouse 27
 20097 Hamburg
 T 040 5559490
 F 040 55594949
 hamburg.anfragen@wilo.de

G3 Sachsen/Th ringen

WILO AG
 Vertriebsb ro Dresden
 Frankenring 8
 01723 Kesselsdorf
 T 035204 7050
 F 035204 70570
 dresden.anfragen@wilo.de

G5 S dwest

WILO AG
 Vertriebsb ro Stuttgart
 Hertichstra e 10
 71229 Leonberg
 T 07152 94710
 F 07152 947141
 stuttgart.anfragen@wilo.de

G7 West

WILO AG
 Vertriebsb ro D sseldorf
 Westring 19
 40721 Hilden
 T 02103 90920
 F 02103 909215
 duesseldorf.anfragen@wilo.de

G2 Ost

WILO AG
 Vertriebsb ro Berlin
 Juliusstra e 52-53
 12051 Berlin-Neuk lln
 T 030 6289370
 F 030 62893770
 berlin.anfragen@wilo.de

G4 S dost

WILO AG
 Vertriebsb ro M nchen
 Landshuter Stra e 20
 85716 Unterschlei heim
 T 089 4200090
 F 089 42000944
 muenchen.anfragen@wilo.de

G6 Rhein-Main

WILO AG
 Vertriebsb ro Frankfurt
 An den drei Hasen 31
 61440 Oberursel/Ts.
 T 06171 70460
 F 06171 704665
 frankfurt.anfragen@wilo.de

Kompetenz-Team Geb udeteknik

WILO AG
 Nortkirchenstra e 100
 44263 Dortmund
 T 0231 4102-7516
 T 01805 R•U•F•W•I•L•O*
 7•8•3•9•4•5•6
 F 0231 4102-7666

Erreichbar Mo-Fr von 7-18 Uhr.

- Antworten auf
- Produkt- und Anwendungsfragen
- Liefertermine und Lieferzeiten
- Informationen ber Ansprechpartner vor Ort
- Versand von Informationsunterlagen

Kompetenz-Team Kommune Bau + Bergbau

WILO EMU GmbH
 Heimgartenstra e 1
 95030 Hof
 T 09281 974-550
 F 09281 974-551

Werkskundendienst Geb udeteknik Kommune Bau + Bergbau Industrie

WILO AG
 Nortkirchenstra e 100
 44263 Dortmund
 T 0231 4102-7900
 T 01805 W•I•L•O•K•D*
 9•4•5•6•5•3
 F 0231 4102-7126

Erreichbar Mo-Fr von
7-17 Uhr.

Wochenende und feiertags
9-14 Uhr elektronische
Bereitschaft mit
R ckruf-Garantie!

- Kundendienst-Anforderung
- Werksreparaturen
- Ersatzteilfragen
- Inbetriebnahme
- Wartung
- Technische Service-Beratung
- Funktionsprobleme
- Qualit tsanalyse

Wilo-International

sterreich

Zentrale Wien:
 WILO Handelsgesellschaft mbH
 Eitnergasse 13
 1230 Wien
 T +43 5 07507-0
 F +43 5 07507-15

Vertriebsb ro Salzburg:
 Gnigler Stra e 56
 5020 Salzburg
 T +43 5 07507-0
 F +43 5 07507-15

Vertriebsb ro Ober sterreich:
 Trattnachtalstra e 7
 4710 Grieskirchen
 T +43 5 07507-0
 F +43 5 07507-15

Schweiz

EMB Pumpen AG
 Gerstenweg 7
 4310 Rheinfelden
 T +41 61 8368020
 F +41 61 8368021

Standorte weiterer Tochtergesellschaften

Aserbaidshon, Belarus,
 Belgien, Bulgarien, China,
 D nemark, Estland, Finnland,
 Frankreich, Griechenland,
 Gro britannien, Irland, Italien,
 Kanada, Kasachstan, Korea,
 Kroatien, Lettland, Libanon,
 Litauen, Montenegro,
 Niederlande, Norwegen,
 Polen, Portugal, Rum nien,
 Russland, Schweden, Serbien,
 Slowakei, Slowenien,
 Spanien, Tschechien, T rkei,
 Ukraine, Ungarn, USA

Die Adressen finden Sie unter
www.wilo.de oder
www.wilo.com.

Stand Januar 2007

* 14 Cent pro Minute aus
 dem deutschen Festnetz
 der T-Com